

City of Warrenton Urban Renewal Agency
Joint Work Session — Urban Renewal Agency & WURAC
Agenda
Tuesday, January 13, 2026 – 5:00 PM
City Hall, 225 S. Main, Warrenton, OR 97146

The meeting will be broadcast via Zoom at the following link

<https://us02web.zoom.us/j/5332386326?pwd=VHNVVXU5blkxuDZ2YmxISWpha0dhUT09#success>

Meeting ID: 533 238 6326 | Passcode: 12345 | Dial-in Number: 253-215-8782

- 1. Call to Order**
- 2. Roll Call**
- 3. Discussion Items**
 - A. Project Prioritization
 - B. Peterson Property
- 4. Adjournment**

Warrenton City Hall is accessible to the disabled. An interpreter for the hearing impaired may be requested under the terms of ORS 192.630 by contacting Hanna Bentley, City Recorder, at 503-861-0823 at least 48 hours in advance of the meeting so appropriate assistance can be provided.



Urban Renewal Agency Agenda Memo

Meeting Date: January 13, 2026
From: Esther Moberg, City Manager
Item Name: Project Prioritization

Summary:

Review current priority list including updates from Executive Director with discussion to follow regarding items that may be removed or added. Update new priority list for 2026-2027.

Recommendation/Suggested Motion:

Alternative:

Fiscal Impact:

Attachments:

1. WURAC FINAL PRIORITY LIST 2025-2027
2. WURAC FINAL PRIORITY LIST 2025-2027 executive director update Jan 2026
3. Slide Deck for Urban Renewal Joint Work Session 2026.01.13

URBAN RENEWAL AGENCY

2025-2027 Priority Project List

1. Commercial E Dock
 - a. Design Phase 2025-2026 \$450,000
 - b. Remainder of funds toward build 2026-2027
2. Stormwater Infrastructure 1st & Main near fishstix
 - a. Design Phase 2025-2026
 - b. Build Phase 2026-2027
3. Spruce Up Warrenton Holiday Street Signs (2) \$40,000
 - a. Purchase 2025-2026
4. Marina Campground \$50-100,000
 - a. 2026-2027
5. 104 Intersection \$25,000
 - a. 2026-2027
6. Covered Outdoor Structure \$1,000,000

Urban Renewal Building Purchase List

1. Library Building \$750,000
 - a. 2025-2026
2. Dairy Maid \$550,000
 - a. 2026-2027
3. Williamson lot behind arnie's (81021AC0860)

Significant Properties Grant list:

1. Methodist Church
 - A. \$50-100,000
2. Former Gas Station
3. Empty Lot on 2nd & Anchor

URBAN RENEWAL AGENCY

Executive Director Update
January 2026

Highlighted Yellow is a new update or completed item, highlighted gray, executive director feels may no longer be an action item.

2025-2027 Priority Project List

1. Commercial E Dock
 - a. Design Phase 2025-2026 \$450,000 – Under contract 2026
 - b. Remainder of funds toward build 2026-2027
2. Stormwater Infrastructure 1st & Main near fishstix
 - a. Design Phase 2025-2026 – (design will begin in next 1-3 months)
 - b. Build Phase 2026-2027
3. Spruce Up Warrenton Holiday Street Signs (2) \$40,000
 - a. Purchase 2025-2026 – Completed
4. Marina Campground \$50-100,000
 - a. 2026-2027
5. 104 Intersection \$25,000
 - a. 2026-2027
6. Covered Outdoor Structure \$1,000,000 (Currently not under consideration)

Urban Renewal Building Purchase List

1. Library Building \$750,000
 - a. 2025-2026 – Offer has been made 1/2026.
2. Dairy Maid \$550,000
 - a. 2026-2027 (Owner has no interest in selling at this time).
3. Williamson lot behind arnie's (81021AC0860)

Significant Properties Grant list:

1. Methodist Church
 - A. \$50-100,000
2. Former Gas Station
3. Empty Lot on 2nd & Anchor

URBAN RENEWAL

2026-2027



URBAN RENEWAL END DATE AUGUST 28, 2027

Current outstanding projects

- Peterson Property/Design Phase
- 1 outstanding floodproofing item for 69 NE Heron Ave
- Library building purchase
- Design of 1st & Main stormwater
- Commercial E dock design
- Finalizing last façade grant



URBAN RENEWAL END DATE AUGUST 28, 2027

“Through implementation of the Plan, economic development will be stimulated by the elimination of blighting conditions, provision of supporting public facilities, and general improvements in the overall appearance, condition, and function, of the downtown, marina, and the District in it’s entirety.”

-From Warrenton Oregon urban renewal plan
June 2007.





TOTAL BUDGET REMAINING:

- **Across 2025-2027: \$2.36 million**
 - **2025-2026 \$1.360 million (\$1,360,000) (Currently encumbered:**
 - **2026-2027 \$1 million (\$1,000,000)**



Lists for priority projects URA

City Projects

City Projects		
E Dock - Design		
Library Building		
Warrenton Campground		
Stormwater 1 st & Main - Design		
Post Office		
Interior Drainage		

Priority Lists

City Projects	Significant Properties	Miscellaneous Projects
E Dock	<i>Updated list</i>	Covered Area
Library Building	Methodist Church	Power Pole Bulbouts
Warrenton Campground	Lighthouse park	104 intersection tree planting/welcome sign
Stormwater 1 st & Main	945 S. Main Ave	
Post Office		
Removed from discussion: El Compadre & Dairy maid	Removed from discussion: Empty Lot on Anchor Ave (2 nd Ave), 1012 S. Main & 238 N Main (former gas station)	Also removed from discussion: 160 S. Main (currently library) & 44 S. Main (lighthouse park)



Urban Renewal Agency Agenda Memo

Meeting Date: January 13, 2026
From: Esther Moberg, City Manager
Item Name: Peterson Property

Summary:

Updated Peterson design for final review and approval.

Recommendation/Suggested Motion:

Alternative:

Fiscal Impact:

Attachments:

1. Peterson Property Concept A 2025.12.01
2. Peterson Property Concept B 2025.12.01



- CONCEPTUAL AMENITY KEY**
- 1 BENCH
 - 2 TRASH RECEPTACLE & DOG WASTE BAG STATION
 - 3 PAVED MULTI-USE PLAZA SPACE (DECORATIVE STAMPED PATTERN OPTIONAL)
 - 4 PROPOSED SIDEWALK
 - 5 PEDESTRIAN PATHWAY (GRAVEL) (PAVED OPTIONAL)
 - 6 BUFFER/SCREENING PLANTING AREA
 - 7 REMOVABLE BOLLARDS/CHAINS AT ENTRANCE
 - 8 ENTRANCE COLUMN SIGN
 - 9 LIGHTED BOLLARDS
 - 10 PAVED PEDESTRIAN PATH CONNECTION TO SIDEWALK
 - 11 ELECTRICAL & WATER HOOKUP (LOCKING LID)
 - 12 STREET LIGHTING

DECORATIVE FENCE SCREEN
 Decorative fence panels feature local themes of flora and fauna, while screening the pedestrian use areas from more utilitarian functions such as the mechanical equipment and parking lot.



MULTI-USE PLAZA
 The paved plaza, with asphalt or concrete surfacing, provides a flexible, pedestrian friendly space that can be used for pop-up events, or farmers market stalls.



ENTRY COLUMN SIGN
 Decorative entry columns at the plaza entrance provide visual separation between pedestrian and vehicular oriented space. Materials can be customized to represent local character.

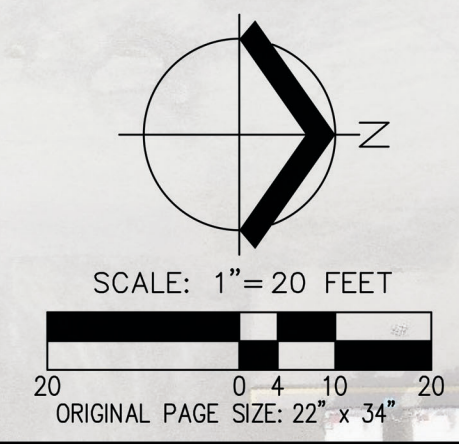

PARK CONCEPTUAL MASTER PLAN - OPTION A
PETERSON PROPERTY PARK



DECORATIVE FENCE SCREEN
 Decorative fence panels feature local themes of flora and fauna, while screening the pedestrian use areas from more utilitarian functions such as the mechanical equipment and parking lot.



MULTI-USE PLAZA
 The paved plaza, with asphalt or concrete surfacing, provides a flexible, pedestrian friendly space that can be used for pop-up events, or farmers market stalls.



ENTRY COLUMN SIGN
 Decorative entry columns at the plaza entrance provide visual separation between pedestrian and vehicular oriented space. Materials can be customized to represent local character.

- CONCEPTUAL AMENITY KEY**
- 1 BENCH
 - 2 TRASH RECEPTACLE & DOG WASTE BAG STATION
 - 3 PAVED MULTI-USE PLAZA SPACE (DECORATIVE STAMPED PATTERN OPTIONAL)
 - 4 PROPOSED PARKING LOT
 - 5 PEDESTRIAN PATHWAY (GRAVEL) (PAVED OPTIONAL)
 - 6 BUFFER/SCREENING PLANTING AREA
 - 7 REMOVABLE BOLLARDS/CHAINS AT ENTRANCE
 - 8 ENTRANCE COLUMN SIGN
 - 9 LIGHTED BOLLARDS
 - 10 ELECTRICAL & WATER HOOKUP (LOCKING LID)
 - 11 STREET LIGHTING
 - 12 OVERFLOW MULTI-USE/PARKING AREA

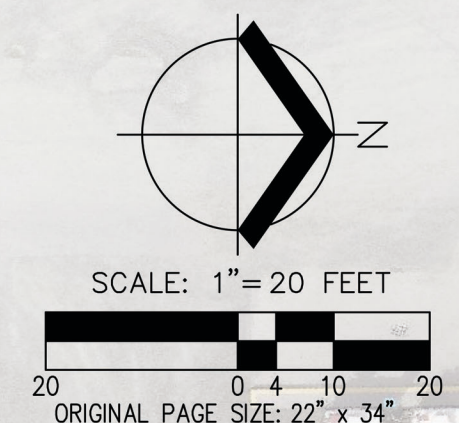

PARK CONCEPTUAL MASTER PLAN - OPTION B
PETERSON PROPERTY PARK